

DRINKS | Countertop Cabinets

DRINK COOLER ▶ UPRIGHT COOLERS

RCF 60

CUSTOMIZATION AVAILABLE
PERSONALIZZAZIONE DISPONIBILE

40 mm	K1	+0°C +7°C	C ENERGY CLASS	CC1	+25°C 60RH
Key	Door	Water	Compressor	Fan	GAS R600a
					LED

DETAILS

Inner LED light and assistance fan	Lock fitted as standard	Independent light switches for inner light
		Foamed door handle

GENERAL FEATURES

- 60 Lt. Upright drink cooler
- External in black coated plate, black aluminium internally
- Roll-bond evaporator system with fan assisted cooling
- Manual Defrost
- Foaming Agent Cyclopentane (40mm per side)
- Removable Gasket
- Independent switch for internal light
- Double layer safety tempered glass
- Self Closing Door
- Lock fitted as standard
- Adjustable shelves (Black Color): 3 Pcs
- N.4 Adjustable feet
- Energy efficiency class: C

TECHNICAL SPECIFICATIONS

Capacity	67 L
Temperature	K1 (0°C-+7°C)
Consumption	0.558 kWh/24h
Rated Power	80 W
Noise level	45 dB
Net Weight	32.5 Kg
Gross Weight	34.5 Kg
External Dimensions (WxDxH mm)	432x496x672
Internal Dimensions (WxDxH mm)	356x368x557
Packaging dimensions (WxDxH mm)	486x552x705
Loading quantities 20'/40'/40'HQ	144/288/288

PRODUCT DIMENSIONS

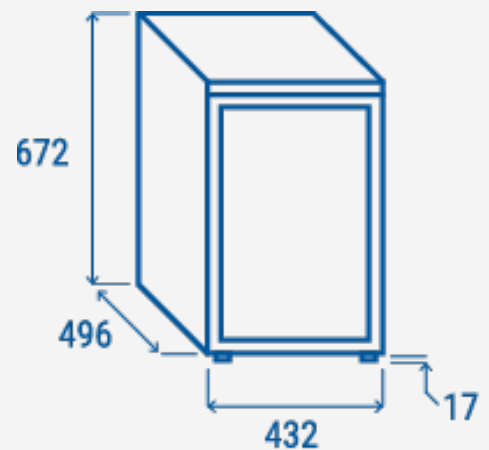

CERTIFICATION

CE RoHS

